



Carmex
Precision Tools Ltd.

New

Modular Line

**Turning adaptors and boring bars
for internal applications of threading and grooving.**



Advantages

- High accurate turning ML adaptors provide full flexibility and easy adjustment.
- Full repeatability.
- A single boring bar fits to multi ML adaptors.
- Reduces tool inventories - investing in a single boring bar, right and left hand ML adaptors from the same size.
- ML adaptors support all Carmex standard thread turning inserts sizes 16, 22 and 27 mm. Grooving inserts size 16 mm fit the MLR/L 16 - 32 and MLR / L 16 - 40 adaptors.
- ML adaptors are coated with a high abrasive resistant nickel layer to prolong the ML adaptors tool life.

Applications

- Internal machining
- Deep threads require high overhang with maximum rigidity
- Grooving
- Can be used on a large range of turning or multi-task machines

High pressure coolant

ML boring bars and adaptors are designed with internal coolant allowing high pressure up to 120 Bar.

High pressure coolant reduces the cutting edge temperature, provides a better chip evacuation and improves tool life.

The tools can also be used with normal coolant pressure.

Product Identification

Ordering Codes: ML Turning adaptors

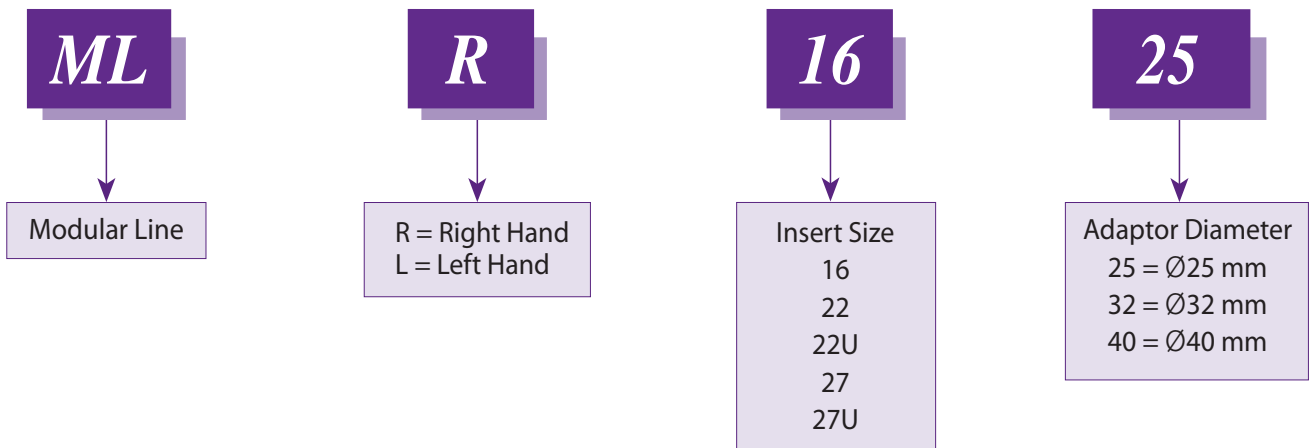

Ordering Codes: Boring Bars



ML Turning Adaptors

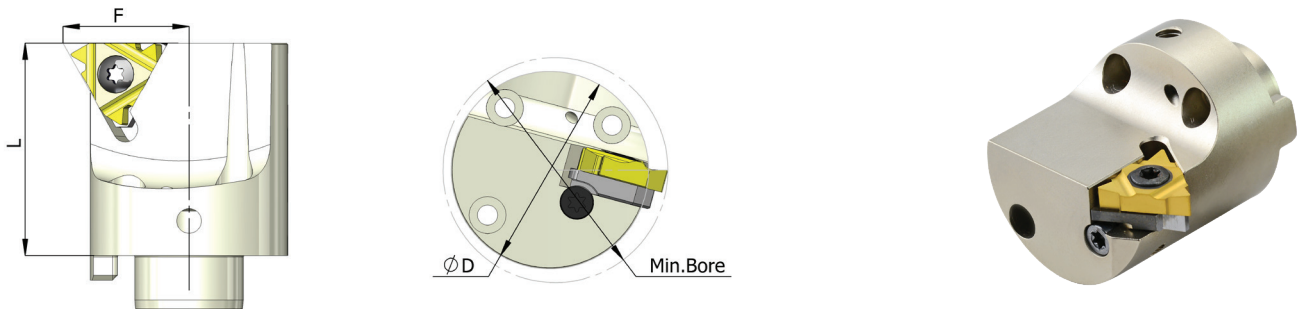

D	Ordering Code	 L	I.C. in	Min Bore Diam.	L	F	Insert Screw	Anvil Screw	Torx Key	RH Anvil	LH Anvil
25	*MLR 16 - 25	16	3/8	29	30	16.2	S16P	-	K16P	-	-
25	*MLR 22 - 25	22	1/2	29	30	18.1	S22P	-	K22P	-	-
32	MLR 16 - 32	16	3/8	36	43	19.7	S16P	A16P	K16P	AI16	AE16
32	MLR 22 - 32	22	1/2	38	43	21.6	S22P	A22P	K22P	AI22	AE22
32	MLR 22U - 32	22U	1/2U	38	43	24.4	S22P	A22P	K22P	AI22U	AE22U
40	MLR 16 - 40	16	3/8	44	43	23.7	S16P	A16P	K16P	AI16	AE16
40	MLR 22 - 40	22	1/2	46	43	25.6	S22P	A22P	K22P	AI22	AE22
40	MLR 22U - 40	22U	1/2U	46	43	28.1	S22P	A22P	K22P	AI22	AE22
40	MLR 27 - 40	27	5/8	48	43	26.6	S27P	A27P	K27P	AI27	AE27
40	MLR 27U - 40	27U	5/8U	48	43	29.4	S27P	A27P	K27P	AI27U	AE27U

*Toolholders with no anvil

For **LEFT HAND** toolholders specify **MLL** instead of **MLR**

Boring Bars

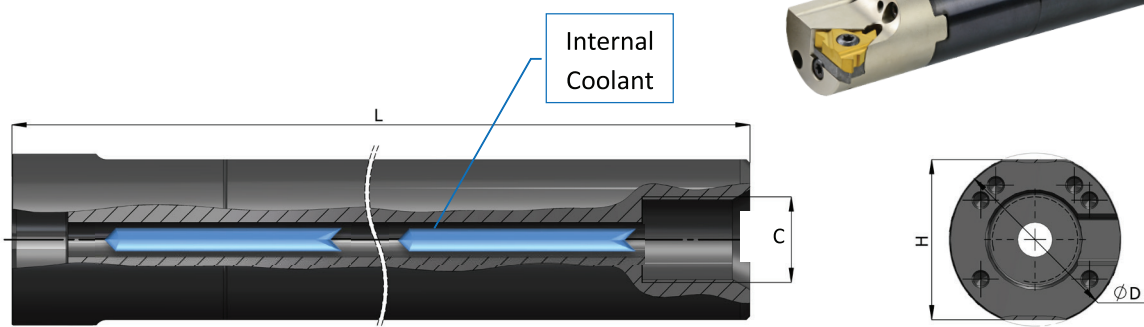

D	Ordering Code	L	H	C	Screw	Key
25	MLS 0025 R	200	23	G1/4"	S420, S435	K3
32	MLS 0032 S	250	30	G3/8"	S520, S550	K4
40	MLS 0040 T	300	36	G1/2"	S520, S550	K4

External ML adaptors (for external threads) are available upon request and can be used on the same MLS boring bars.



Carmex
Precision Tools Ltd.

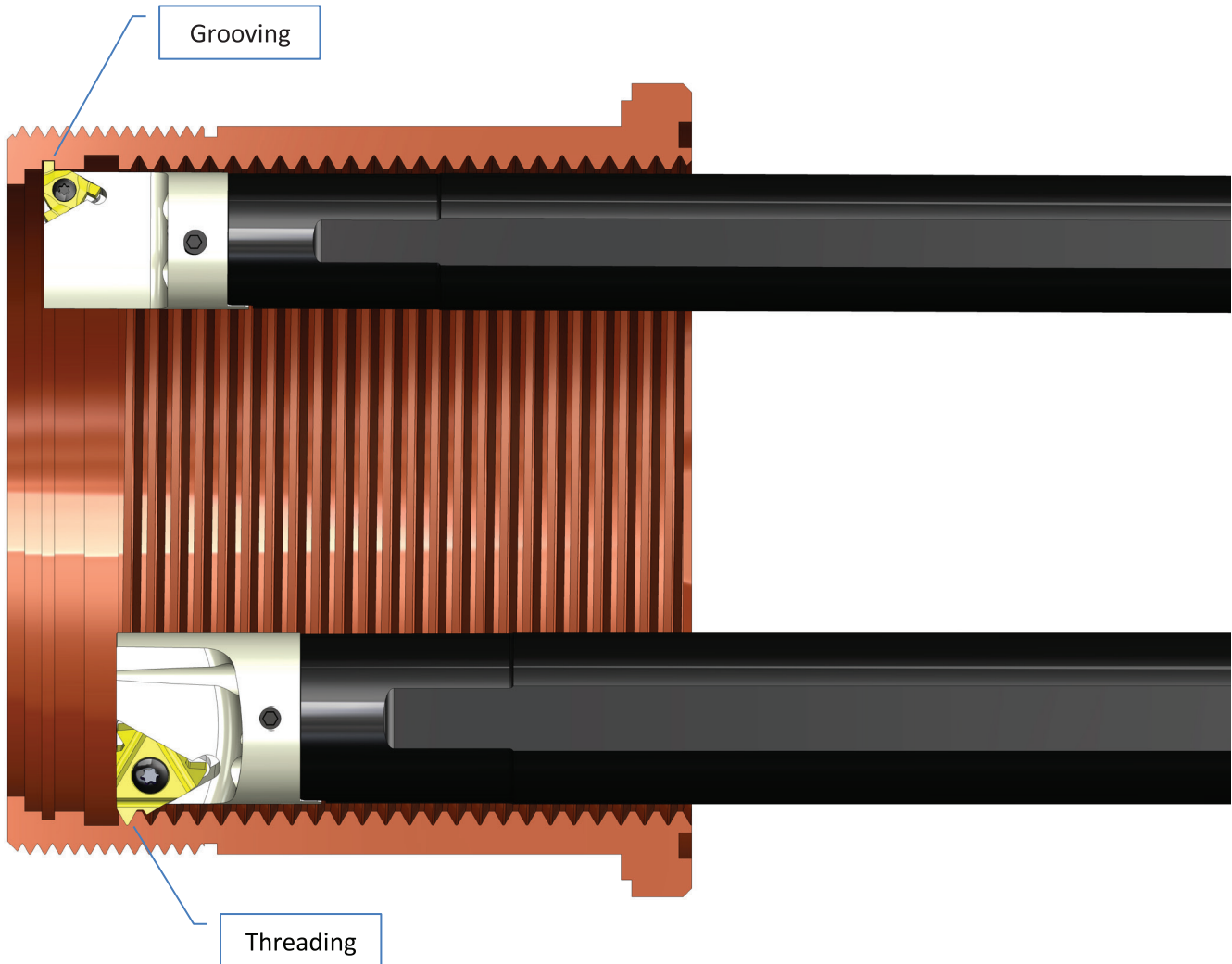

- Maximum overhang: 4 x D

1 Hacharoshet St., Maalot Industrial Zone 2101302, ISRAEL
Tel: (972) 4-9077400, Fax: (972) 4-9077440.
E-mail: info@carmex.com Website: www.carmex.com
Postal address: P.O. Box 404, Maalot 2101302, ISRAEL.